



Technical Information Bulletin 10-2007 (NL20071015) Page 1 of 4

Installation of Inverters for Operation of Air-Conditioning Systems, Coffeemakers or Similar Large Consumers

Subsequently equipping a motorhome with an inverter represents a major intervention in the energy budget of the power supply system. This has already been described in detail in Technical Information Bulletin NL20060512 of the Schaudt GmbH company.

Successful installation in a manner satisfactory for the customer is possible only if the electrical system is modified substantially. The following points in particular must be observed:

- The current consumption in the motorhome increases substantially owing to inverter operation. This means that far more battery capacity is required.
- The maximum consumer current to be provided is now far higher.
- The existing standard equipment may not be impacted in a negative way. Current metering must be taken into consideration in particular in the case of electrical installations with capacitance metering.
- An inverter is a device that generates high frequency or radio frequency. Besides having CE conformity, it must also have been issued an E1 Type Approval by the Federal Bureau of Motor Vehicles and Drivers (KBA) in Germany if it can be operated while on the move.

This solution proposal has allowed for the above aspects, and the aim was to continue use of the standard electrical equipment and supplement it, i.e. not to exchange the standard equipment wherever possible, so as to save costs.

The following additional components are essentially required:

- One or more additional batteries
- Additional cut-off relay
- Auxiliary charging unit
- Additional wiring with fuse
- A higher-amperage alternator

The block diagram shows an example of such an installation. The standard equipment of a motorhome equipped with a Schaudt Electrobloc (EBL) and a suitable digital display panel (DT) with capacity display is shown above the dashed line.

Most of the additional components required and mentioned above are shown below the dashed line.

Technical Information Bulletin 10-2007 (NL20071015) Page 2 of 4

Installation of Inverters for Operation of Air-Conditioning Systems, Coffeemakers or Similar Large Consumers

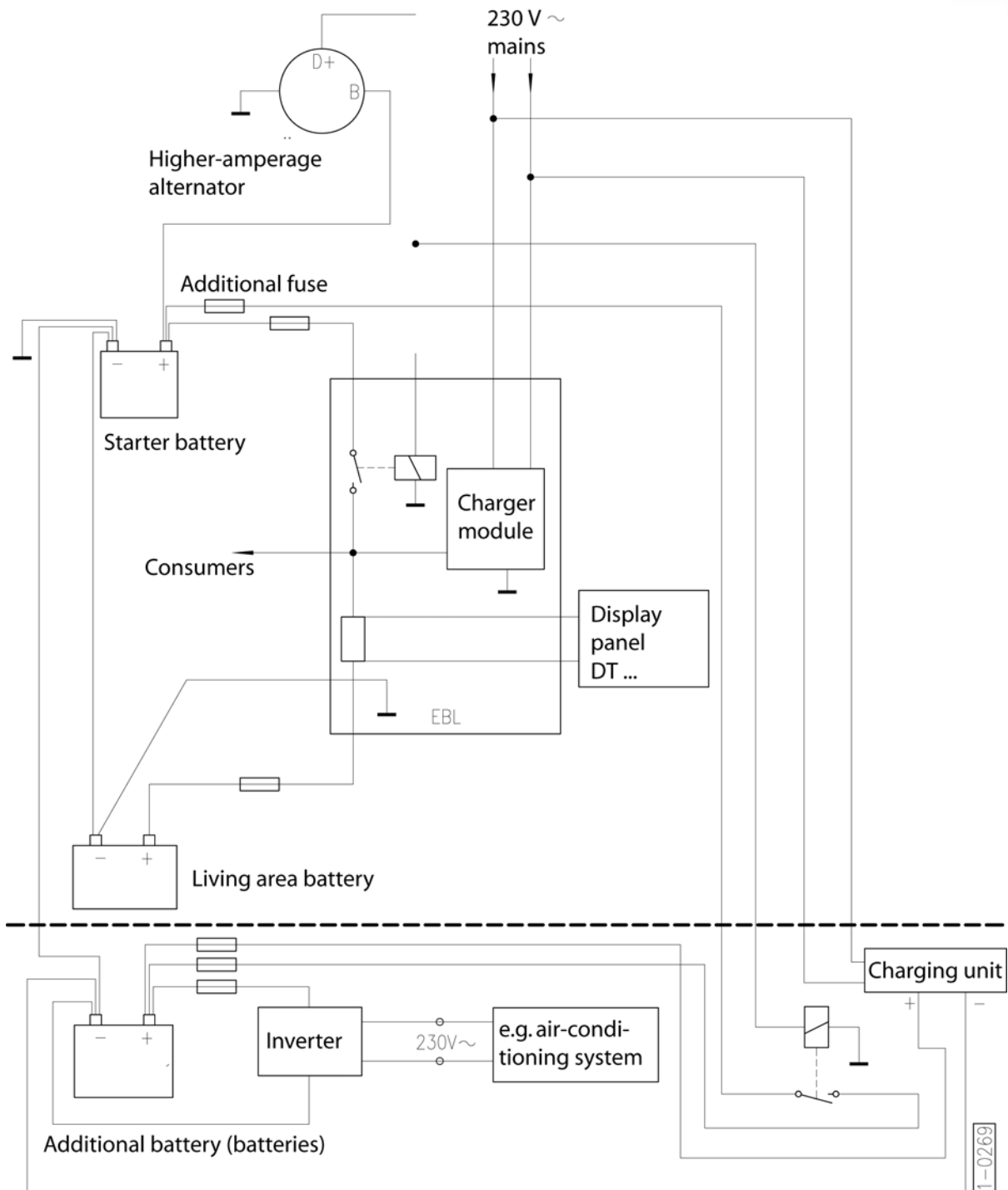

Additional components for installation of an inverter in a motorhome with battery capacity display (EBL/DT)



Technical Information Bulletin 10-2007 (NL20071015) Page 3 of 4

Installation of Inverters for Operation of Air-Conditioning Systems, Coffeemakers or Similar Large Consumers

This concept uses an additional power supply battery that powers the inverter and that is separate from the standard living area power supply battery. This additional battery is also connected to the alternator by means of a separate, additional cut-off relay only when the vehicle is on the move, so as to charge the additional battery as well. This is why the alternator must have a higher amperage rating than that of the normal standard equipment. An additional charging unit is also required for charging the inverter battery (additional battery) in the case of mains operation.

The concept described in this paper has the following aspects:

- Power supply battery and inverter battery are separate.
- The independent inverter supply circuit is consequently not monitored by the battery capacity display, thus preventing malfunctions of the battery display. In addition, no costly adaptations of the living area battery display are required.
- No "running down" of the power supply battery owing to long operation of inverter (luxury) consumers and the associated failure of important equipment such as refrigerator, heater and pumps etc.
- The battery capacity available to the inverter is lower owing to separate power supply. However, it is not necessary to allow for other consumers.

Since certain components required (e.g. adequately rated cut-off relay, appropriate battery lugs or fuses) are not easily available on the market, Schaudt will package a set of parts certainly required. These parts will probably be available as of November 2007.



Technical Information Bulletin 10-2007 (NL20071015) Page 4 of 4

Installation of Inverters for Operation of Air-Conditioning Systems, Coffeemakers or Similar Large Consumers

Information Bulletins previously available:

NL20071015	Installation of Inverters II	(October 2007)
NL20060804	OVP 01 – 230 V Overvoltage Protection	(August 2006)
NL20060512	Installation of Inverters	(May 2006)